

IN OUR VIEW, FORM DEVIATION IS NOT A QUESTION OF PERCEPTION. **THAT IS WHY WE HAVE MARFORM**



The latest information on MARFORM products can be found on our website:
www.mahr.com, WebCode 20575, 20570, 21052



▶ | To ensure the problem-free functioning and durability of a workpiece, the key factors are its dimensions and, above all, its form. Requirements in terms of roundness, flatness, straightness, coaxiality or run-out – particularly when it comes to axis-symmetrical workpieces – are becoming increasingly tough. These requirements can only be reliably tested and met using high-precision formtesters optimized for this specific purpose. Whether you are dealing with fuel injection technology, microelectronics, precision mechanics or medical technology, the key functional components are becoming ever smaller and ever more precise. To enable the production department to take advantage of the specified tolerances, measuring uncertainty must be kept as low as possible. MarForm helps you to cut process costs without increasing testing costs thanks to stable, innovative instruments with the highest possible level of automation, flexibility and precision. MarForm offers the ideal solution for all requirements.

▶ | MarForm. Form Measuring Instruments

Formtesters

MarForm MMQ 100	16- 3
MarForm MMQ 150	16- 4
MarForm MMQ 200	16- 5
MarForm MMQ 400-2	16- 6
MarForm. Overview standard measuring machines	16- 7

Reference Formtesters

MarForm MFU 100	16- 9
MarForm. Overview reference and large Formtesters	16-10
MarForm MFK 500 / 600	16-11

MarWin. Software modules for MarForm	16-12
Software Packages for Special Applications	16-15

Accessories for MarForm	16-21
--------------------------------	--------------

MarForm. Formtesters for a Wide Range of Applications

FORM MEASURING INSTRUMENTS FOR THE WORKBENCH OR INSPECTION ROOM

▶ | There are many aspects of our daily lives where we need to be able to rely on technical components functioning correctly. Take for example the ABS braking system, injection system or gearbox of a car, the drive of a PC, the compressor in an air-conditioning system, the blade of an electric razor or the landing flaps of an aircraft. For the moving components to function efficiently over long periods of time, it is vital they work together smoothly. To ensure this is the case, axis-symmetrical workpieces with narrow tolerances from the ideal are needed. Compliance with these tolerances can only be verified reliably using precision formtesters that have been specifically optimized for this application. MarForm helps you to cut process costs without increasing testing costs thanks to stable, innovative instruments exhibiting the highest possible precision. MarForm offers the ideal solution for all requirements.

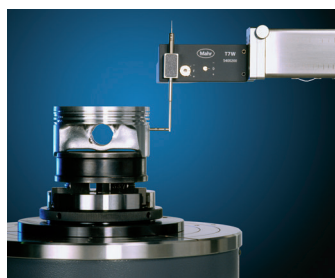
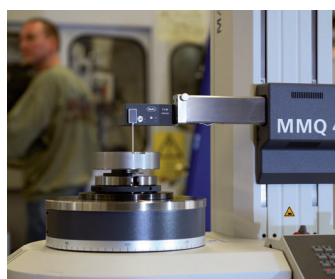

MarForm MMQ 100

The Formtester with the simplest operation



Formtester MarForm MMQ 100



Features

The **MarForm MMQ 100 Formtester** offers outstanding accuracy in a robust package designed for use in production environments. Used in combination with **EasyForm** software, it represents the perfect solution for performing measurement tasks simply, yet effectively.

- Precise and fast measurement results
- Reliable thanks to mechanical bearings
- Large measuring volume
- Mobile due to its low weight and convenient size
- Fast computer-assisted workpiece alignment
- Centering and tilting screws for rough and fine adjustment
- Universal and reliable
- Suitable for use on the shop floor as no compressed air connection is required
- No keyboard or mouse required
- Digital encoders in Z and X transmit the measuring position directly to the software

The **MMQ 100** can also be operated from a laptop, thereby enabling mobile use. All you need is a power outlet!

Optimized for the most frequent form measuring tasks

- Roundness (also in a section)
- Flatness (from a circle)
- Concentricity
- Coaxiality
- Radial run-out
- Axial run-out
- Plane parallelism from opposite circles
- Fourier/waviness analysis

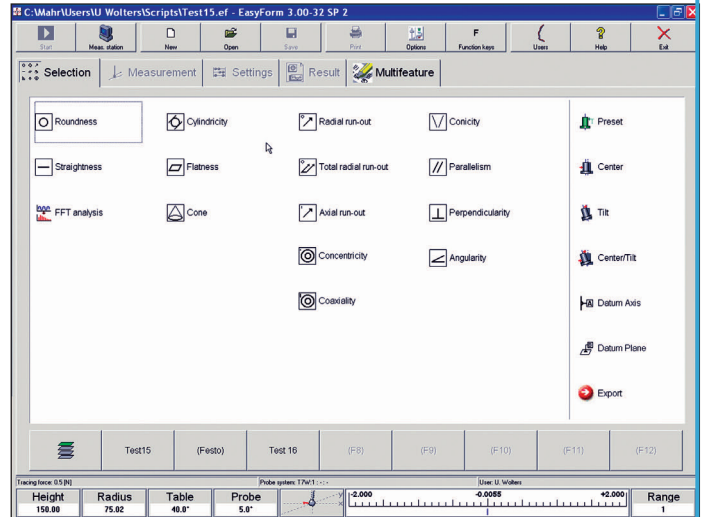

EasyForm

Versions

MMQ 100 with EasyForm as a powerful, PC-based evaluation system running on Windows® 7 offers informative color records with easy-to-use software for evaluation of form and positional tolerances (DIN ISO 1101) such as roundness, roundness sector, radial run-out, axial run-out, concentricity, coaxiality, flatness⁽¹⁾, straightness⁽¹⁾, parallelism⁽¹⁾ and perpendicularity⁽¹⁾.

The **MMQ 100 EasyForm measuring station** comes complete:

Form Measuring Station MMQ 100

consisting of:
 MarForm MMQ 100 with digital encoders in X/Z and with T20W probe
 Measuring and operating software EasyForm
 PC Intel class, Windows 7 Ultimate 64 bit
 24" TFT monitor

Options for MMQ 100:

Advanced Form for comprehensive evaluations, based on EasyForm
 17" Touch-Screen monitor

Mahr Data Transfer Tools for simple transfer of measuring results into statistical evaluation programs such as QS-STAT or MS Excel.



Request a brochure or see WebCode 20571

(1) from either a single or several polar traces

MarForm MMQ 150

The MMQ 150 - The entry into the world of cylindricity metrology



Features

An overview of the most important features of the MMQ 150:

- High-precision roundness measuring machine (C)
- Motorized vertical measuring axis (Z)
- Motorized horizontal positioning axis (X)
- Manual centering and tilting table
- Manual length measuring probe T20W
- Ergonomic operating panel enables the activation of selected measuring programs (P1, P2, P3)
- Compact, space-saving construction
- All-in-One touchscreen PC
- Easy to use and intuitively learnable software EasyForm

Options

- Rim chuck \varnothing 100 mm
- Various other damping devices
- Option commutator evaluation
- Option Velocity Analysis
- Probe arms with different length and probe ball geometries
- Various double probe arms
- Various calibration standards
- Various unit tables, also with vibration compensation

Description

The MMQ 150 is an automatic measuring machine for the testing of form and location tolerances:

- Use in production or measuring room
- Fast and easy operation
- Measuring accuracy, optimized for cylindricity tolerances
- Reduces number of rejected parts, saves time, lowers production costs
- Maintenance-free, high-precision mechanical bearings

The MMQ 150 measuring station offers you a complete system solution for the monitoring of form and position tolerances for the quality assurance of your products. The MMQ 150 was designed for accuracy, speed and easy operation, all in a very compact construction. Only highly precise, maintenance-free mechanical bearings are used, thus eliminating the need for regular maintenance and exchange of compressed air components.

The use of mechanical air bearings have been successfully used for many years in other Mahr formtesters, such as the table formtester MMQ 400 and reference formtester MFU 100. The interplay of rotary table axis and vertical axis have been optimized in such a manner, that the MMQ 150 is especially suited for the measurement of cylinder form tolerance deviations. The operating and measuring software EasyForm is very easy to use and can be intuitively learned. No programming knowledge is required in order to perform a simple measurement with measuring record in only a few steps. With the help of the teach-in programming included in the software, program runs with a user-defined complete measuring record can just as easily be created. The created measuring programs can easily be activated via the user interface with the 32 freely available operation keys or the 3 freely configurable program keys on the operation panel of the MMQ 150.

Applications

- Roundness
- Concentricity / Coaxiality
- Cylindricity
- Radial run-out
- axial run-out
- Total radial run-out (from circular traces) (1)
- Straightness
- Parallelism
- Perpendicularity (from a circular trace) (1)
- Angularity
- Flatness (from a circular trace) (1)
- Conicity
- Taper
- Fourier analysis

MarForm MMQ 200

The MMQ 200 is the standard form measuring instrument for both your shop floor and precision inspection rooms

Description

Characteristics of MarForm MMQ 200

- High-precision roundness measuring axis (C)
- Motorized measuring axis vertical (Z)
- Motorized positioning axis horizontal (X)
- Manual tilting and centering table
- Manual length measuring probe T20W or
- Motorized probe T7W
- Ergonomic control panel, also starts selected measuring programs (P1, P2, P3)

Versions

MarForm **MMQ 200** is available in two versions. As a measuring station with the universal measuring probe **T20W** and as a measuring station with the motorized measuring probe **T7W**, allowing for an additional level of automation due to its unique motorization.

The **MMQ 200** is operated with the software **EasyForm**. Operation takes place with touchscreen technology and is thus also for the mouse operation unique and easy.

Form measuring station with T20W

- Formtester MarForm MMQ 200
- Length measuring probe T20W, manual, with probe arm
- Measuring and operating software EasyForm
- PC Intel class, Windows 7 Ultimate 64 bit
- 24" TFT monitor
- Deskjet printer with cable
- Rim chuck with diameter of \varnothing 100 mm

Form measuring station with T7W

- Formtester MarForm MMQ 200
- Motorized length measuring probe T7W with probe arm
- Measuring and operating software EasyForm
- PC Intel class, Windows 7 Ultimate 64 bit
- 24" TFT monitor
- Deskjet printer with cable
- Rim chuck with diameter of \varnothing 100 mm

Options:

- 17" touchscreen TFT monitor instead of 24" standard TFT monitor
- Option roughness measurement and evaluation with MMQ 200/T7W
- Software AdvancedForm (expanded functionality and programming)
- Different clamping devices
- Probe arms with different lengths and probe ball geometries
- Different double probe arms
- Different calibration standards

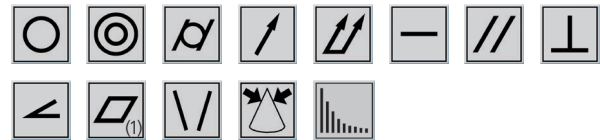

Features

The **MMQ 200** features a high-precision motorized Z column, opening up a whole new dimension in form metrology compared to the roundness measuring instrument **MMQ 100**.

The Formtester **MarForm MMQ 200** fully-automatically determines the following form and location deviations as per DIN/ISO 1101 so that you can verify the quality of your products:

- Roundness
- Straightness
- Flatness (from a single polar trace)⁽¹⁾
- Parallelism
- Conicity
- Concentricity, coaxiality
- Run-out, total radial run-out
- Cylindricity
- Taper
- Perpendicularity (from a single polar trace)
- Pitch
- Angular sector (from roundness, flatness or run-out)
- Evaluation of straightness sections



Request a brochure or see WebCode 20573

(1) from either a single or several polar traces

MarForm MMQ 400-2

The MMQ 400-2 is the universal form measuring machine for both your shop floor and precision inspection rooms

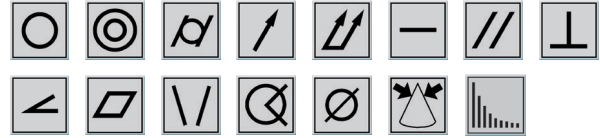

Features

The **MMQ 400-2** is the universal measuring machine for extensive workpiece evaluation as per DIN ISO 1101. High-precision measuring axes in Z and X make every form measurement task possible.

MarForm MMQ 400-2 for:

- High-precision workpieces
- Unusually long workpieces
- Large and heavy workpieces
- Use in production environments or precision inspection rooms

The **MarForm MMQ 400-2** is available in five versions which are designed to meet your requirements and solve any of your measuring tasks.

- Motorized or manual centering and tilting table
- Vertical axis (Z) with measuring length of either 500 mm (19.67 in) or 900 mm (35.4 in) and horizontal axis (X) with measuring length of 280 mm (11.02 in) or
- Vertical axis (Z) with measuring length of 350 mm (13.78 in) and horizontal axis (X) with measuring length of 180 mm (7.09 in)
- With digital position decoders in the linear axes X and Z for best reproducibility of measurements.

Your **MarForm MMQ 400-2** is available as a semi-automated measuring station with manual centering and tilting table or as a fully automated measuring station which, in conjunction with a motorized centering and tilting table and T7W probe, is perfect for the high-precision testing of your parts without any operator intervention.

Motorized Form Probe T7W

The **T7W** probe is fitted with a motor-driven rotational axis. This makes it possible to move the probe arm in steps of less than one degree to the required contacting position. Measurements can be performed on the generating surfaces and end faces. As a zero position probe, the **T7W** can also switch automatically between internal and external measurements or between end face measurements from above and below without operator intervention. Fully automatic measurement processes on complex workpieces can be carried out without operator intervention too.

The probe arms of the **T7W** are exchangeable. Its motor-driven rotational axis enables the construction of "multi-point probe arm units" - i.e. probe arm units with a variety of contacting elements - making it possible to switch between different stylus ball geometries within a single measurement run.

Option Roughness Measurement

Combine the testing of form and location tolerances with roughness parameter monitoring.

Document typical roughness parameters such as R_a and R_z while testing the form of your workpieces with a **MarForm MMQ 400-2**, without having to set up the workpiece on a different measuring station.

The motorized, program-controlled change between the form probe arm with ruby ball and the roughness probe arm PHT 6-350 makes it possible. Without user intervention, the corresponding probe arm is automatically positioned from the vertical contacting position to the horizontal one. The motorized swivel axis of the form probe T7W is used here for positioning the probe arm unit in increments of 1°.



Request a brochure or see WebCode 20574

MarForm Overview of Standard Form Measuring Machines



Formtester	MMQ 100	MMQ 150	MMQ 200 Z= 250 mm	MMQ 400-2 Z = 350 mm/ X = 180 mm Z = 500 mm/ X = 280 mm	MMQ 400-2 Z = 900 mm X = 280 mm
Roundness measuring unit, C-axis					
Roundness deviation ($\mu\text{m}+\mu\text{m}/\text{mm}$ meas. height)**	0.05 + 0.0006	0.03 + 0.0006	0.03 + 0.0006	0.02 + 0.0005	0.02 + 0.0005
Roundness deviation ($\mu\text{m}+\mu\text{m}/\text{mm}$ meas. height)*	0.025 + 0.0003	0.015 + 0.0003	0.015 + 0.0003	0.01 + 0.00025	0.01 + 0.00025
Axial run-out ($\mu\text{m}+\mu\text{m}/\text{mm}$ meas. radius)**	0.04 + 0.0006	0.04 + 0.0006	0.04 + 0.0006	0.04 + 0.0002	0.04 + 0.0002
Axial run-out ($\mu\text{m}+\mu\text{m}/\text{mm}$ meas. radius)*	0.02 + 0.0003	0.02 + 0.0003	0.02 + 0.0001	0.02 + 0.0001	0.02 + 0.0001
Centering and tilting table					
	manual	manual	manual	man. / autom.	autom.
Table diameter (mm)	160	160	160	285	285
Table load, centric (N)	200	200	200	600	400
Revolutions per minute (rpm) 50 Hz / 60 Hz	5 / 6	1 to 6	1 to 15	1 to 15	1 to 15
Vertical straightness measuring unit, Z-axis					
Positioning path (mm)	300, manual		-	-	-
Measuring path motorized (mm)	-	250	250	350 / 500	900
Straightness deviation /100 mm meas. path (μm)**	-	0.4	0.15	0.15	0.15
Straightness deviation /total meas. path (μm)**	-	1	0.3	0.3 / 0.4	0.4
Parallelism deviation Z-/C-axis in tracing direction ($\mu\text{m}/\text{mm}$)	-	1	-	0.5 /350 0.8/500	2 / 900
Measuring speed (mm/s)	-	0.5 to 20	0.5 to 5	<0.1 to 10	<0.1 to 10
Positioning speed (mm/s)	-	0.5 to 50	0.5 to 100	<0.5 to 100	<0.5 to 100
Horizontal straightness measuring unit, X-axis					
Positioning path (mm)	man. 180.	mot. 150	mot. 150	-	-
Measuring path, motorized (mm)	-	-	-	180 / 280	280
Straightness deviation/100 mm meas. path (μm)**	-	-	-	0.4 / 0.8	1.5
Straightness deviation /total meas. path (μm)**	-	-	-	0.8/180 0.8/280	1.5
Perpendicularity X-/C-axis (μm)	-	-	-	1/180 2/280	2
Positioning speed (mm/s)	-	0.5 to 30	0.5 to 30	<0.5 to 30	<0.5 to 30
Measuring speed (mm/s)	-	<0.5 to 10	<0.5 to 10	<0.5 to 10	<0.5 to 10

* Values as max. deviation from reference circle LSC, filter 15 upr.

** All values acc. to DIN ISO 1101 at 20 °C \pm 1 °C in oscillation-neutral environment, filter 15 upr LSC or 2.5 mm LSS, 5 rpm or 5 mm/s and standard probe arm with ball \varnothing 3 mm. Tested on a standard using compensation algorithms. Due the vast variety of Formtester types and variants, only a few machines are described as examples. Technical data of "your" MMQ can be received from Mahr upon request.

MarForm. The Reference Machines for Form and Positional Tolerances OUR MOST ACCURATE FORM MEASURING INSTRUMENTS EVER

▶ | **High-precision form measurements cut costs!** MarForm is the name of our ultra-precise form measuring systems. They can be used wherever there is a need to obtain information about the geometry of workpieces with very narrow tolerances. ISO 1101 describes roundness, cylindricity, straightness, parallelism etc. as form and positional deviations. These features are all monitored by Formtesters. The high precision of form measuring instruments cuts costs because the tolerance ranges are no further narrowed by the uncertainty of the measuring machine but can be fully exploited in production. With MarForm, you have a high-precision roundness and cylindricity measuring instrument at your disposal. | ◀

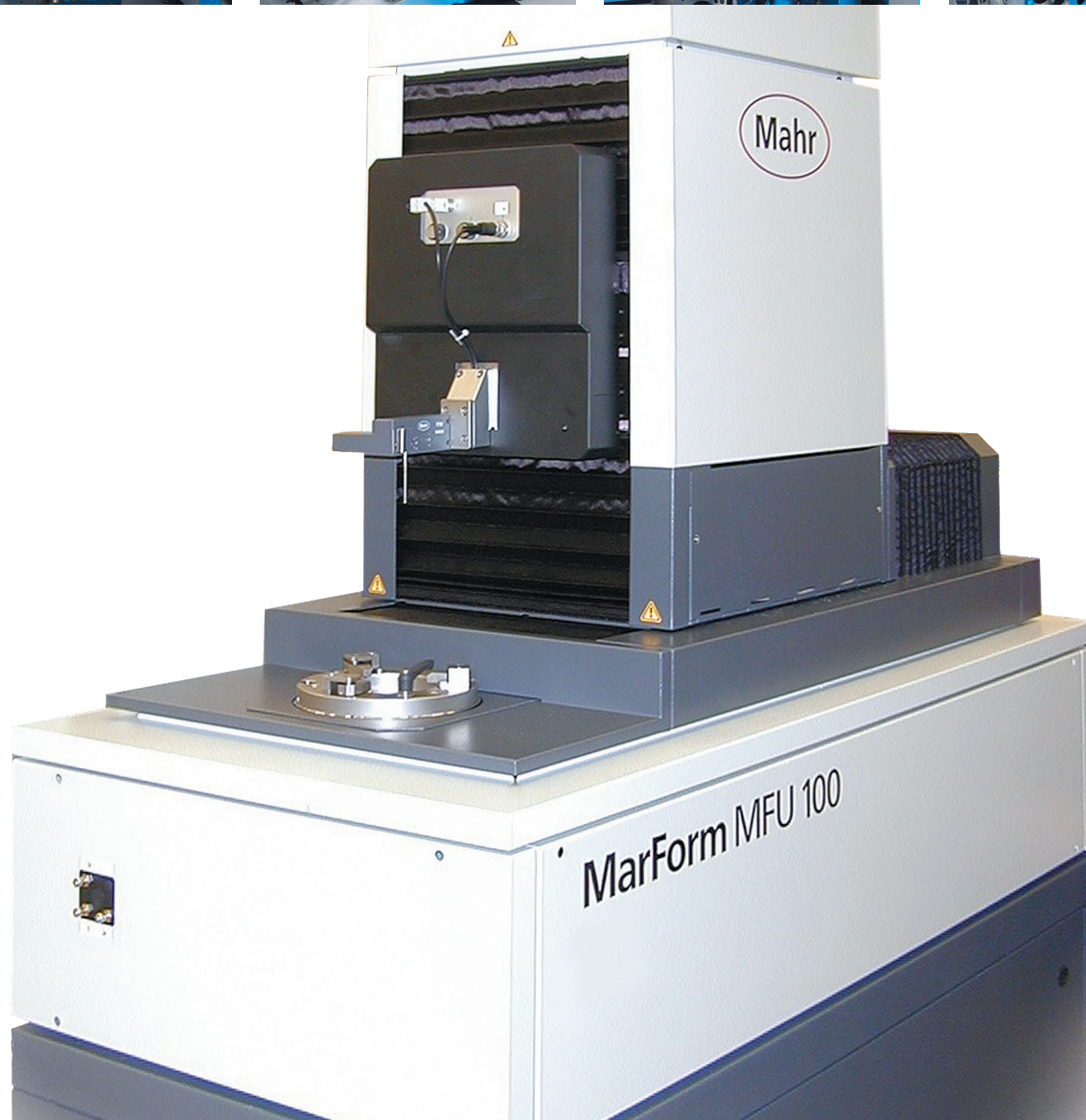
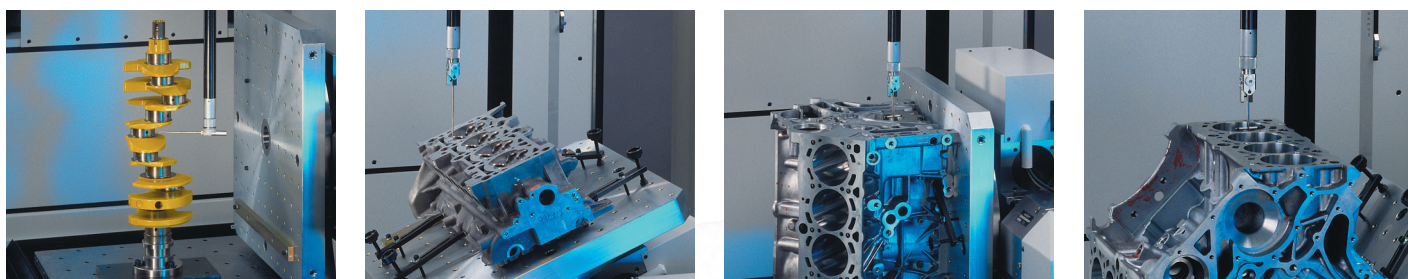

MarForm MFU 100

Taking reference form measurement to a new level

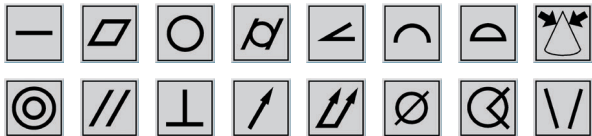

The road from high-precision measuring axes to reliable measurements is often a long one – and no instrument is better suited for this purpose than the **MFU 100**. Only the **MFU 100** has integrated reference elements for real-time spatial compensation of geometrical deviations and therefore records all profiles as high-precision 3D coordinates.

For decades, MarForm measuring instruments have been renowned for their precision and stability. The new **MarForm MFU 100** was developed with the objective of testing the form and positional features of parts with measuring volumes of a liter cost-effectively in a production environment. Our many years of experience have taken the new **MFU 100** to a new level.

With the **MarForm MFU 100**, you have a high-precision measuring instrument at your disposal whose extremely low measuring uncertainty increases the tolerance range in production environments and thus cuts production costs.

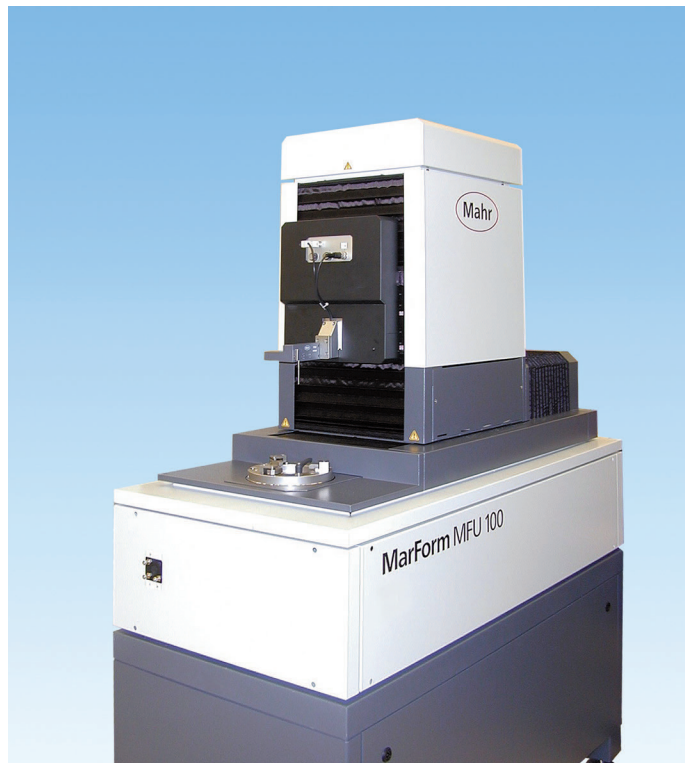

Features

The **MarForm MFU 100** comes complete with:

- Roundness axis, circular (C)
- Motorized centering and tilting table (X, Y, A, B)
- Straightness measuring axis, vertical (Z)
- Straightness measuring axis, horizontal (X)
- Tangential multi-function axis (Y)
- Motorized probe T7W
- MarWin evaluation software for form and positional features

All the axes are coordinated to ensure maximum measuring certainty.

The horizontal X-axis extends beyond the center of the workpiece, therefore making it possible to test the “true parallelism” free from other measuring influences.

The tangential Y-axis is a new and innovative feature. For conventional formtesters. It makes it possible to locate the zenith of very small workpiece geometries automatically and free from user influence. This means that the actual precision measurement can be started at exactly the right location, thus significantly increasing the process accuracy.

In addition, the tangential Y-axis, in combination with the vertical Z-axis and the horizontal X-axis, enables you to determine the workpiece diameter. At a unique price/performance ratio, this axis makes it now possible to verify tolerances in the sub- μm range according to standards using the maximum material principle.

In combination with the machine electronics, high-resolution digital scales ensure a level of positioning quality that makes it possible to test even the smallest component geometries.

The **MarForm MFU 100** is also ideally suited to scanning surfaces.

The **MarWin** software package offers the complete range of functions you would expect from a modern measuring and evaluation software package, including attractive records and electronic documentation in your corporate network.

Due to the deliberate separation of control and evaluation, the **MarForm MFU 100** is future-proof and expandable. New language versions, special evaluations and new standards can all be incorporated with ease. The **MFU 100** has also been designed to accommodate sensors developed in the future.

In short, the **MarForm MFU 100** represents a new generation of reference form measuring instrument for precision inspection rooms and production environments.

The new **MarForm MFU 100 WP** is also available with an optional optical sensor to alternate with the T7W (motorized).



Request a brochure or see WebCode 20576

MarForm Overview Reference and Large Formtesters

Formtester	MFU 100
Roundness measuring device, C-axis	
Roundness deviation ($\mu\text{m}+\mu\text{m}/\text{mm}$ meas. height)**	0.02 + 0.0004
Roundness deviation ($\mu\text{m}+\mu\text{m}/\text{mm}$ meas. height)*	0.01 + 0.0002
Axial run-out deviation ($\mu\text{m}+\mu\text{m}/\text{mm}$ meas. radius)**	0.04 + 0.0004
Axial run-out deviation ($\mu\text{m}+\mu\text{m}/\text{mm}$ meas. radius)*	0.02 + 0.0002
Resolution (interpolated)	0.0001°
Centering and tilting table	
Table diameter (mm)	180
Table load capacity, centric (N)	200
Speed (rpm) 50 Hz/60 Hz	0.1 to 15
Vertical straightness measuring unit, Z-axis	
Measuring path (mm)	320
Straightness deviation /100 mm (μm)**	0.1
Straightness deviation /200 mm (μm)**	0.2
Straightness deviation / measuring path (μm)**	0.3
Parallelism deviation of Z-/C-axis in tracing direction (μm)	0.6
Measuring speed (mm/s)	0.1 to 50
Positioning speed (mm/s)	0.1 to 50
Positioning uncertainty (μm) with probe return positioning	1
Positioning uncertainty (μm) (total positioning P to VDI 3441)	2
Resolution (interpolated) (μm)	0.001
Horizontal straightness measuring unit, X-axis	
Measuring path (mm)	190
Straightness deviation /100 mm (μm)**	0.15
Straightness deviation /meas. path (μm)**	0.3
Perpendicularity of X/C-axis (μm)	0.3
Measuring speed (mm/s)	0.1 to 50
Positioning speed (mm/s)	0.1 to 50
Positioning uncertainty (μm) with probe return positioning	1
Positioning uncertainty (μm) (total positioning P to VDI 3441)	2
Diameter measuring accuracy (μm)	0.2
Resolution (interpolated) (μm)	0.001
Horizontal straightness measuring unit, Y-axis	
Measuring path (mm)	6
Straightness deviation ($\mu\text{m}/5$ mm, filter 0.25 mm)	0.5
Perpendicularity Y-/X-axis (μm)	1
Resolution (interpolated) (μm)	0.005

* Values as maximum deviation from reference circle LSC, filter 15 upr.

** All values in accordance with DIN ISO 1101 at 20 °C \pm 1 °C in vibration-free environment, filter 15 upr LSC or 2.5 mm LSS, 5 rpm or 5 mm/s and standard probe arm with ball dia. 3 mm.
Tested on a standard using compensation algorithms.

MarForm MFK 500 and MFK 600

The reference form measuring centers for laboratories and inspection rooms

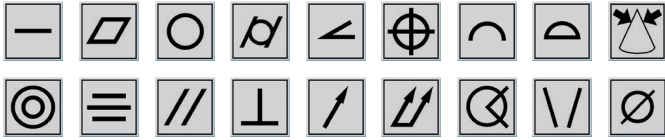

MFK form measuring center for comprehensive workpiece assessment

MFK formtesters are particularly suited to testing engine blocks, cylinder heads, gearboxes, hydraulic components, crankshafts and camshafts.

Generous, optimized construction ensures high measuring accuracy over the entire machine volume. Large measuring and travel paths enable easy and safe changing of workpieces.

The **MarForm MFK 600** and **MFK 500**, made from coordinated components, offer flexibility and can be adapted for a wide range of metrology applications.

The formtester has a distortion-free granite base which is oscillation-isolated. Its high-precision horizontal surface forms the reference plane for the measuring setup. The workpiece mounting table carries and guides heavy workpieces over the granite surface using air bearings.



Features

- Universal form measuring station with large measuring volume for heavy workpieces
- The **MFK 600** has 5 measuring axes and 2 (4) alignment axes for measuring form elements and determining positions
- The **MFK 500** has 3 measuring axes and 4 alignment axes for measuring form elements
- Rotating probe and automatically positioned workpieces for easy use and quick setup
- Low maintenance and able to handle continuous loads thanks to air bearings
- Collision-protected probe systems for a wide range of measurement tasks
- Large workpiece mounting area for large individual workpieces or pallets holding several workpieces
- Roundness measuring unit with automatic adjustment to the diameter of the workpiece even if the position is eccentric
- Straightness measurements in 3 main coordinate directions
- ISO 1101-compliant workpiece evaluation
- Testing in machine and workpiece coordinates in line with manufacturing requirements
- Comprehensive evaluation of form and positional features, diameters and positional values
- A wide range of accessories and probes offer an optimum solution for all measurement tasks
- Easily expandable with additional axes of movement for rotating workpieces while the program is running. This means that highly complex measurement tasks, such as those required for V engine blocks, can be performed without operator intervention

Roundness measuring unit

In addition to the measuring spindle (C-axis), the roundness measuring unit includes an axis for automatically adjusting the probe to the workpiece diameter (X-axis). When performing roundness measurements, the X-axis positions the probe such that it tracks the contour of the workpiece, even if its eccentricity error exceeds the probe measuring range.

Straightness measuring unit

The vertical straightness measuring unit (Z-axis) guides the roundness measuring unit along a granite surface. With the **MFK 600**, the accuracy of the horizontal straightness measuring unit (T_x - and T_y -axes) is not affected by the workpiece's size, form or weight because the guides are separated from the supporting air bearings. With the **MFK 500**, the T_x/T_y -axes of the motorized centering and tilting table are also used as positioning axes.

The **alignment axes** (T_a and T_b) are integrated in the workpiece mounting table and can automatically align workpieces mechanically within the machine volume.

Measuring capacity

Automatic alignment functions integrated in measuring runs allow continuous operation. Recording and processing measured values in parallel cuts the measurement time. The form measuring station's range of applications is extended by a comprehensive range of accessories.



Request a brochure or see WebCode 20580.

MarWin. Software Modules for MarForm

AdvancedForm gives you total control over your form measuring station. You can perform positioning, alignment, measurement or documentation tasks with a click of the mouse – and the graphical user interface gives you a constant overview.

As with other Windows® applications, functions can be selected from menu bars with pull-down menus using the mouse.

Many functions, such as printing results, loading measuring programs or changing a program step, can be activated simply by clicking the appropriate icons.

With **AdvancedForm** you always have complete control over the form measuring station. For example, you can track the profile during measurement and intervene if necessary. Operation can be adapted to suit individual requirements, regardless of whether you want to perform a quick single measurement, conduct a program run on a series part or convert a complex measurement task into a measuring program. **AdvancedForm** provides the ideal operating strategy whatever the task. Given that tasks can vary a great deal, no operating strategy is exactly right for every application.

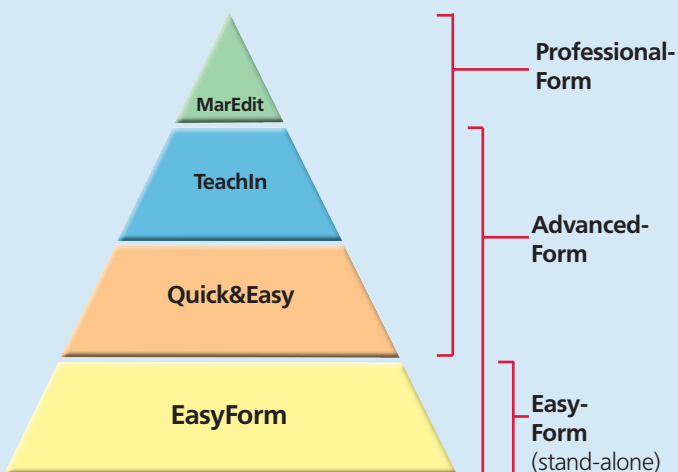

Consequently, **AdvancedForm** provides several different operating strategies:

- **Measuring run preferences**
for measurement with an existing measuring program.
- **Quick&Easy**
for rapid measurement, obtaining a measuring result quickly with the minimum of effort.
- **Teach-in programming**
for creating, modifying and running a measuring program with a large number of options.
- **MarEdit (optional)**
the operating level for applications engineers and trained specialists, to solve the most challenging and complex of tasks.

AdvancedForm provides a clear overview of all the required measuring and evaluation parameters. Many of these parameters have default settings which simply have to be confirmed for the majority of measurement tasks. It is, of course, also possible to adapt individual parameters to the relevant task.

AdvancedForm has a powerful **teach-in programming** function to create measuring programs for workpieces that are to be measured repeatedly. It can also be used for measuring runs with special positionings, measurements, evaluations and forms of presentation.

With teach-in programming, as soon as you click the mouse on an icon – e.g. for a run-out measurement and evaluation – a window opens where you can describe the feature in more detail if necessary (e.g. radial or axial run-out, datum, brief designation, tolerance, etc.). The number of measurements and their type (measurement or re-evaluation of profiles already measured) are also specified in this window. Separate windows can be opened to change measuring, evaluation and display parameters but in many cases this is not necessary because logical defaults that apply to a large number of measurement tasks have already been entered.

If different settings are required for specific measurement tasks, the clearly structured window helps you to quickly find what you are looking for and optimize the settings in no time at all.

The layout of a measuring record, for example, can be modified right down to the finest detail. The color of the profile, reference line and borders can be selected individually; the scaling (in $\mu\text{m}/\mu\text{in}$ per scale division), the type of graph (polar or linear, centered or uncentered) and the additional display parameters can be set in any combination you choose.

Measuring programs for series parts to be measured repeatedly can be saved and called up at any time to start a measuring run (see above).

Informative profile graphs – if required with several profiles in a single graph, displayed in different colors and in different ways – are then immediately available on the large color screen. If you are looking for exact numerical values, you can opt to display the results in a table.

With the new **AdvancedForm**, standards-compliant measurements and evaluations are displayed in a way which is both clear and representative. Even interactive layout options with a 3D preview in real time are possible.

MarWin. Software Moduls for MarForm

MarWin software modules in detail

If you need to carry out form measurements, rather than creating long measuring programs you may prefer to gain direct access to a comprehensive and informative measuring record. In order to be able to do so, it is particularly important for the software to be transparent. Immediately after logging on in the **MarWin** user administration, you are directed to the MarShell, a clearly arranged user interface comparable with the Windows Desktop. It is from this **MarShell** that you start the finished measuring programs in the Preferences view. These preferences can be easily identified by each operator due to expressive images and icons already saved to the system. One click is all that is needed to start the measuring program.

The **MarShell** is also used to start the measuring wizard module, Quick&Easy (QE).

The **Quick&Easy** wizards provide support for "quick measurements by the fly" and, with little effort, guide the user quickly to his objective, namely a highly informative measuring record.

A further click results in all **Quick&Easy** wizards that have so far been run being adopted as a chronological sequence into teach-in programming function of **AdvancedForm/MarWin**.

This sequence merely has to be saved and the measuring program is then ready.

In **AdvancedForm**, additional functions can be added to the measuring program. The following Quick&Easy wizards assist in this process:

1. PREPARATION FOR MEASUREMENT



- QE Determine starting position
- Measuring station, positioning
- QE Axial run-out alignment
- QE Centering
- QE Centering and tilting



- QE Set parameters
- QE Zenith
- QE Edge search
- QE Switch coordinate system
- QE Move to calculated position

2. PROFILE RECORDING



- QE Circles on cylinder
- QE Circles on plane/end face
- QE Lines on cylinder
- QE Lines on plane/end face



Preferences view for starting the measuring programs

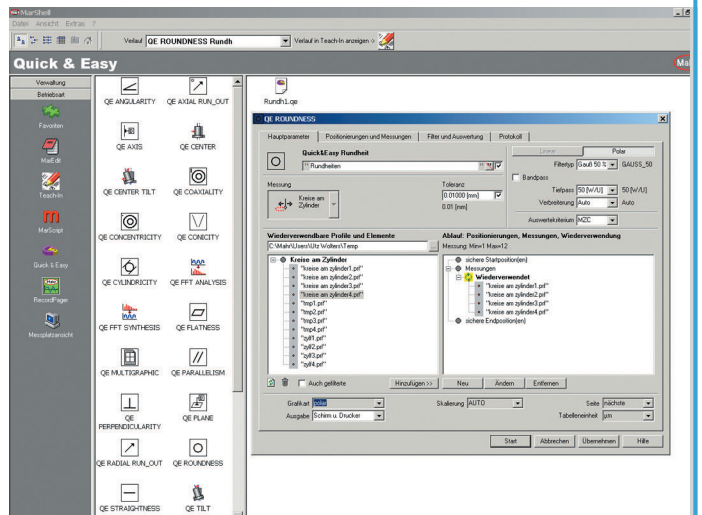

Quick&Easy Roundness

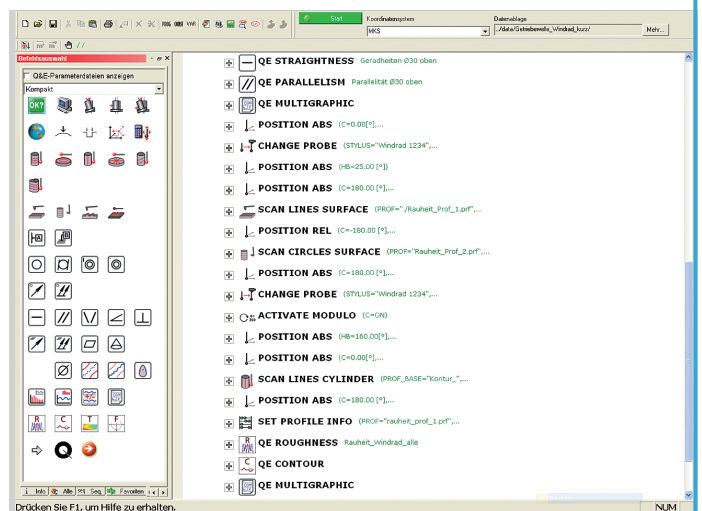

Teach-in listing

MarWin. Software Modules for MarForm

3. EVALUATION



- QE Axis
- QE Plane



- QE Roundness
- QE Cylindricity
- QE Coaxiality
- QE Concentricity



- QE Radial run-out
- QE Total radial run-out



- QE Straightness
- QE Parallelism
- QE Conicity
- QE Angularity
- QE Perpendicularity

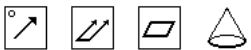

- QE Axial run-out
- QE Total axial run-out
- QE Flatness
- QE Taper

4. SPECIAL EVALUATION

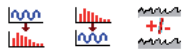

- QE Fourier analysis
- QE Fourier synthesis (optional)
- QE Profile arithmetics
- QE Roughness measurement (optional)
- QE Contour measurement (optional)
- QE Diameter measurement (optional)
- QE Tolerance band evaluation (optional)
- QE Cam evaluation (optional)
- QE Dominant Roundness Waviness (optional)

5. RECORD



- QE Multigraphics

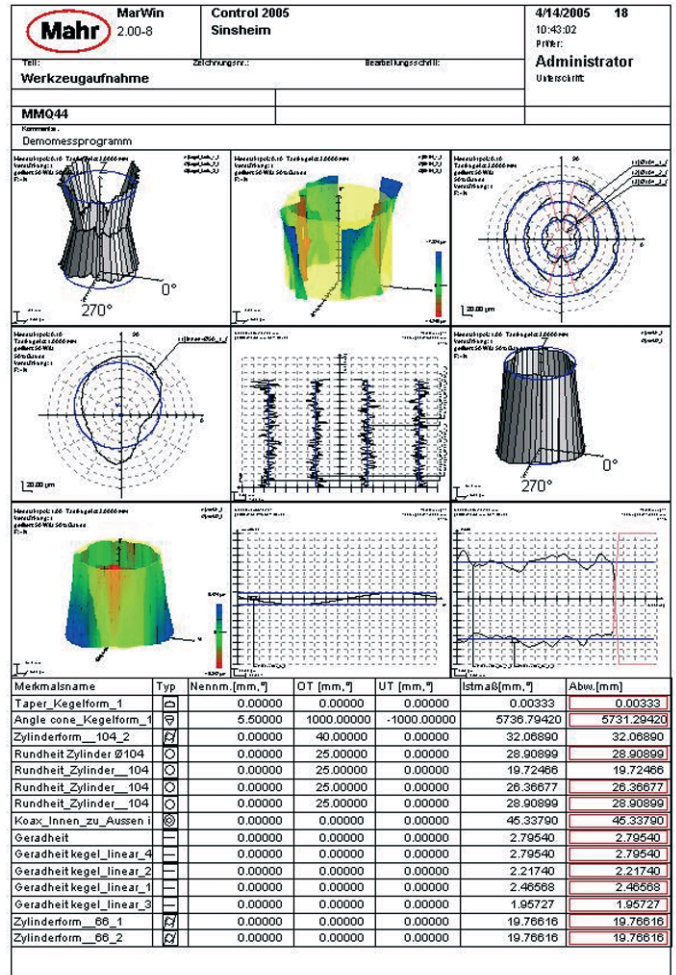

Multigraphic record

6. DATA EXPORT



- QE Result export (optional)
- QE QS-STAT (optional)

Software Packages for Special Applications

Expansion package for piston measurement and evaluation

Can be used in conjunction with **MarForm MMQ 400-2** with **T7W** probe and Mahr's **MarWin** evaluation software, consisting of:

- Software package for piston-specific evaluation based on MarWin evaluation software
- Probe arms for piston measurement optional and customized on request

With the option "Piston measurement and evaluation", piston specific measuring tasks can be carried out, for example

- Determining the position of the main ovality axis
- Determining the position of the pin bore (from segment measurements in the bore) and using this position to determine the angular offset of the main ovality axis
- Testing up to 10 ovalities using tolerance tables (symmetrical and asymmetrical ones) / radius- or diameter-based input and output records for each oval: polar and linear graphs and results table; changes possible upon request depending on the work involved
- Testing 2 meridians using tolerance tables (symmetrical and asymmetrical) / radius- or diameter-based input and output / records: both meridians on a single page with diagram and result table; changes possible upon request depending on the work involved
- Determining the offset of the piston head relative to the piston axis computed
- Testing the following features in the grooves (for each groove, measurements in up to 4 angular positions are possible)
 - Long-wave (0 to 50 upr) and short-wave (15 to 150 upr) portions of upper and lower groove flanks
 - Groove opening angle (total and individual) of trapezoidal grooves, output in either degrees, minutes, seconds or as a decimal
 - Straightness, axial run-out and perpendicularity of upper and lower groove flanks relative to the piston axis
- Determining special linear forms of the piston's pin bore using tolerance tables (e.g. "trumpet shape") in the same clamping (2 measurements for each bore section)
- Determining special linear (e.g. "trumpet shape") and polar (e.g. "ovalities on one side") forms of the piston's pin bore using tolerance tables, clamped with centered bore (up to 4 linear and up to 2 polar measurements for each bore section)

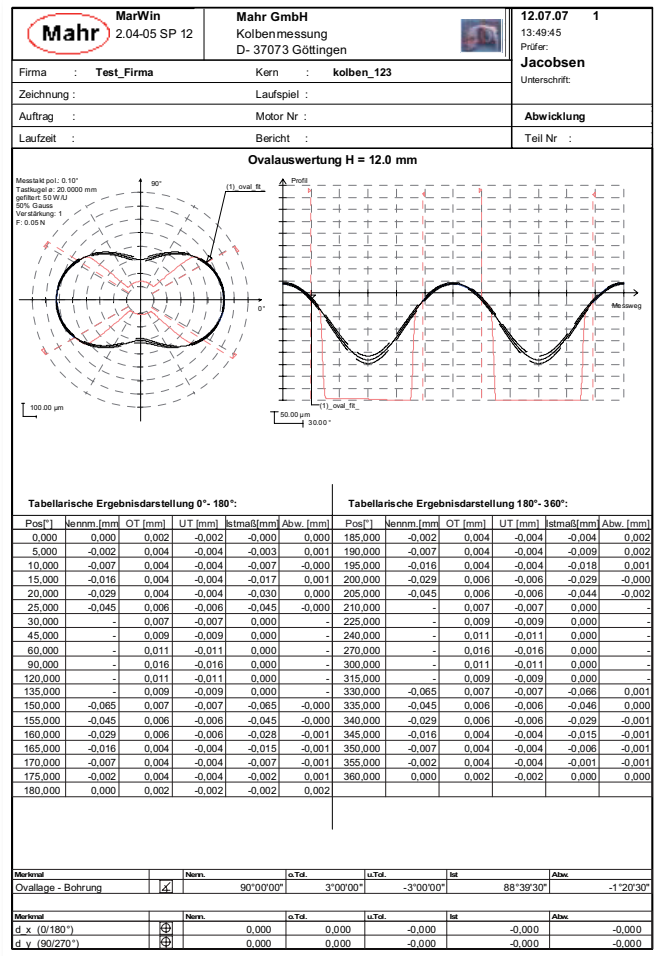
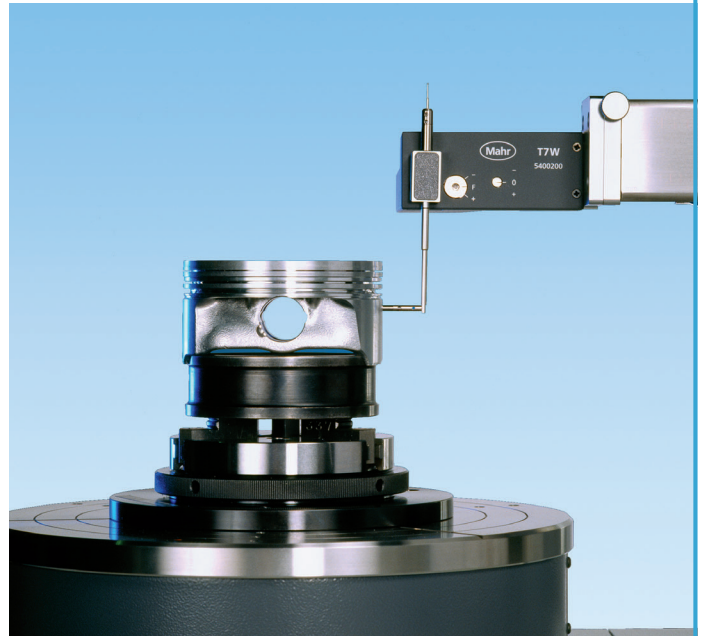

Request a brochure or see WebCode 21056.

MarWin. Lead Measurement and Analysis with MarForm Formtesters

Expansion package for MarForm Formtesters as per Mercedes Benz Standard MBN31007-7, version 2

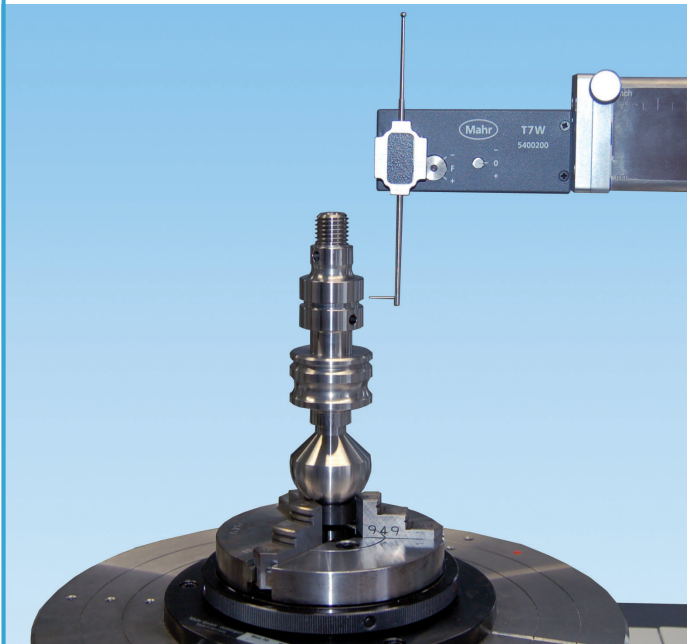

Expansion package: Lead measurement and analysis

For use on MarForm MMQ 200, MMQ 400-2, MFU 100 with motorized probe T7W and the Mahr evaluation software MarWin, consisting of:

- Software package "Lead measurement and analysis" based on MarWin evaluation software
- T7W probe arm unit for lead measurement, double-ended with diamond tip $5\ \mu\text{m}$ and 3 mm hard metal ball for alignment (5400234)

Order no.: 5440675

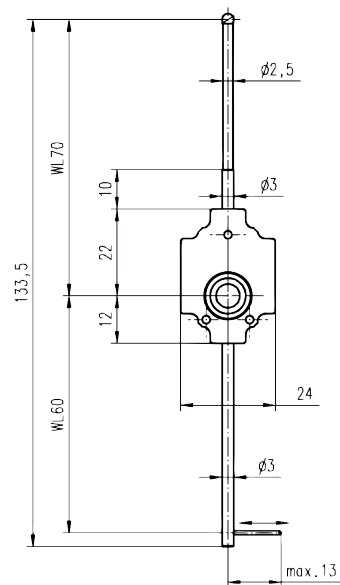
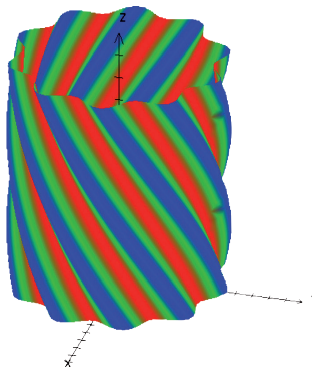

Description

Measured value acquisition

The surface structure of the sealing surface of a shaft influences the flow behaviour of the fluid that is to be sealed and therefore greatly influences the sealing function.

A lead structure on the sealing surface can interfere with both the shaft surface, fluid and sealing lip contact length creating leakage due to a conveying effect.

Lead is a surface feature appearing over the entire circumference on rotationally symmetrical surfaces. The evaluation of the macro lead is conducted with the option "Lead measurement" as per the Mercedes Benz Standard 31007-7.

Measurement of n generating lines (72 as per MB Standard, MBN 31007-7)

A T7W probe arm with two styli is used to assess the measuring values.

- Stylus # 1 with 3 mm hard metal ball for mechanically centering and tilting of the workpiece on the Formtester
- Stylus # 2 with diamond stylus tip for measuring lead and surface roughness parameters

Scope of application

External measurement on workpiece diameters between 2 and 200 mm

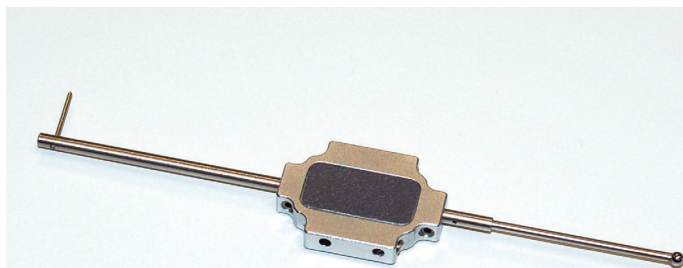

Request a brochure or see WebCode 21055.

Expansion Package for MarForm Formtesters. Lead Measurement and Analysis

Form and lead evaluation

- Form/positional evaluation for conicity / parallelism / parallel to lead evaluation
- Form/positional/lead evaluation of several upr values

Evaluation and recording

After the measurements have been performed, measurement records with the following content are generated:

Lead parameters:

- Number of threads DG (upr)
- Period length DP (mm)
- Lead angle $D\gamma$ (degrees)
- Lead direction
- Lead depth Dt (μm)
- Theoretical supply cross section DF (μm^2)
- Theoretical supply cross section per turn DFu ($\mu\text{m}/\text{U}$)
- Contact length of radial seal DLu (%)

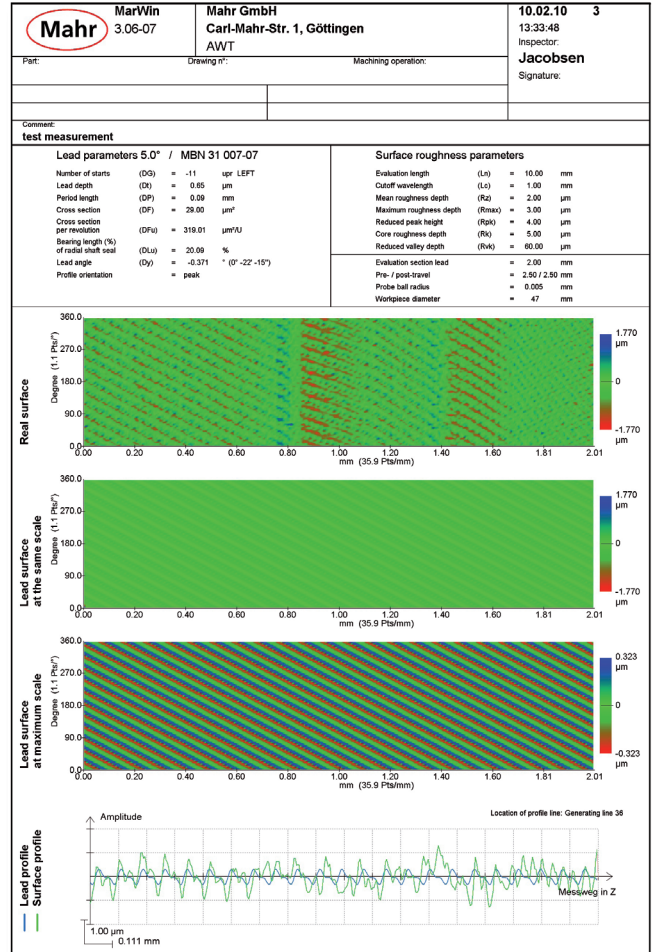

Record lead measurement

Graphic output:

The measured profiles are output in the record as graphs.

Various diagram types are available:

- 3D cylinder (in color, traditional and unwound)
- Every assessed generating line profile is shown in a linear graph to judge the form and the positional parameters.
- Amplitude spectra of the linear profiles in a bar graph

Or as per MBN 31007-7: unwound 3D cylinder colored

- Surface structure
- Lead surface
- Display of surface profile and lead profile

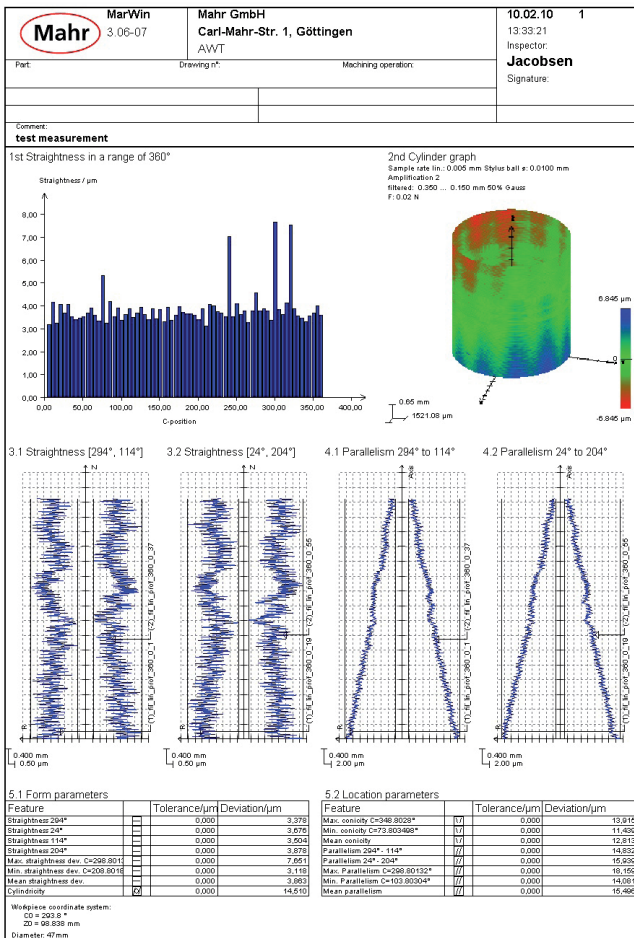

Roughness Measurements with MarForm Formtesters

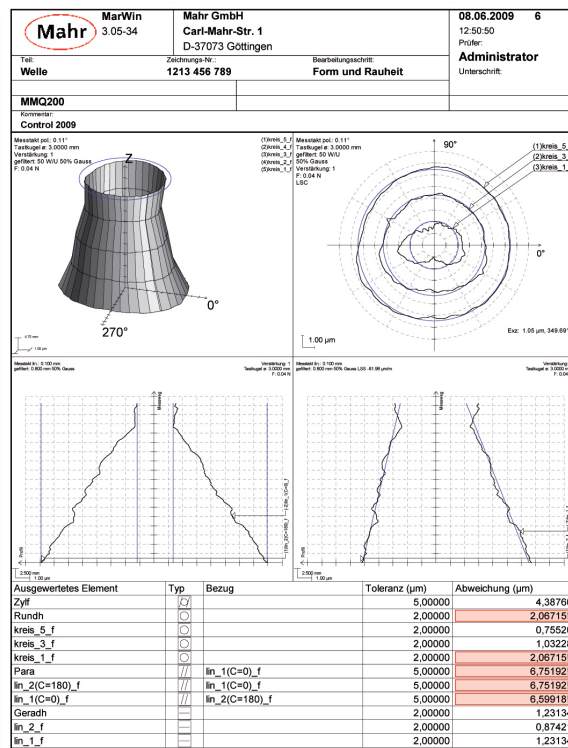

What is more obvious than assessing and documenting the surface roughness parameters of your workpiece while checking it for form and positional tolerances?

Why not assess e.g. the Ra and Rz values with a MarForm form measuring instrument?

User benefits:

If you do so, you can be sure of uncompromisingly high quality for the pick-up or probe required for the relevant measuring task is always in optimum measuring position.

Profit from:

- Reduced testing times and costs due to complete workpiece assessment in a single set up and in just one run
- Higher accuracies due to the automatic selection and positioning of the probe or pick-up for each measuring task
- Simple operation due to a software which is equally well suited for surface roughness as well as form and position measurements
- Detailed and telling measuring records
- Well-proven surface roughness metrology combined with equally well-proven form metrology

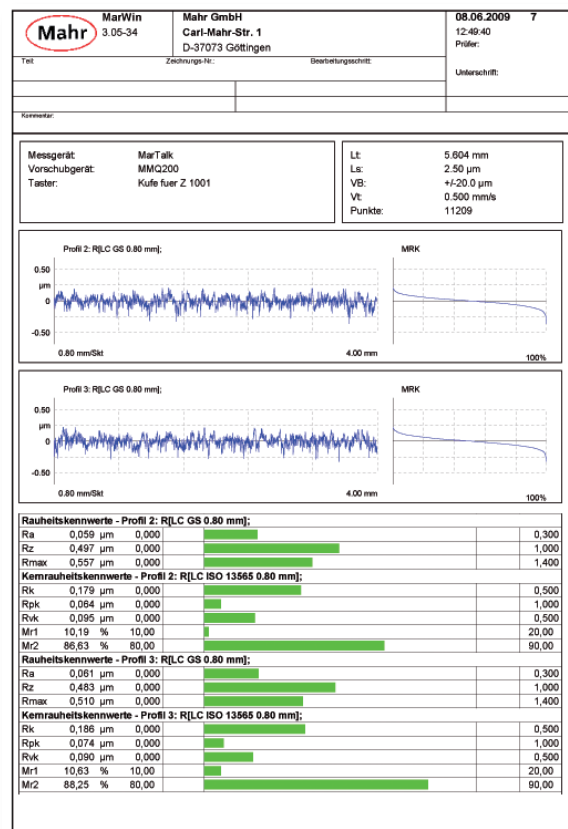

Roughness Measurements with MarForm Formtesters

Mahr as the market leader in the field of form metrology offers form measuring machines of utmost precision and for many customers Mahr measuring machines are the standard in mechanical form metrology. And the very well proven stylus method has been perfected at Mahr

Mahr, the specialist for inductive probes, combines the advantages of its universal motorized **T7W** probe with the precision of its **PHT 6-350** pick-up. Probe and pick-up grow together. The MarForm MMQ automatically swivels the probe or pick-up required for the measuring task to the optimum measuring position!

This is possible as the change between the form probe with ruby ball and the **PHT 6-350** pick-up with diamond tip is fully-automatic and program-controlled. Changing from vertical to horizontal measuring positions is also fully automatic. Owing to the rotary axis of the **T7W** probe which positions any probe arm in steps of less than 1° with utmost precision, operator interventions are completely superfluous.

Combine the testing of form and positional tolerances with the monitoring of roughness parameters. Record and file typical surface roughness parameters such as Ra and Rz while checking the dimensional stability of your workpieces on a MarForm MMQ in one go. You will not be bothered with having to clamp it again on a surface roughness measuring station.

In addition to the possibility to measure the surface roughness parameters with the PHT 6-350 pick-up attached to the T7W probe arm unit, it is also possible to assess the parameters with just a diamond stylus attached to the T7W probe arm unit. This application strategy is suitable when, for example, the **PHT 6-350** cannot be used due to its geometry or when the tolerances for the roughness Rz lies in the range of $> 2 \mu\text{m}$. The double point probe arm unit is swivelled automatically without any user interference when contacting with the diamond stylus or the ruby ball is required.

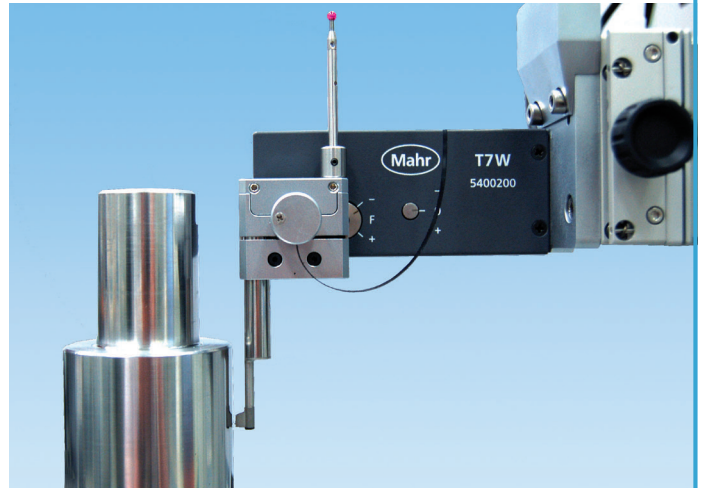

T7W with PHT measuring head

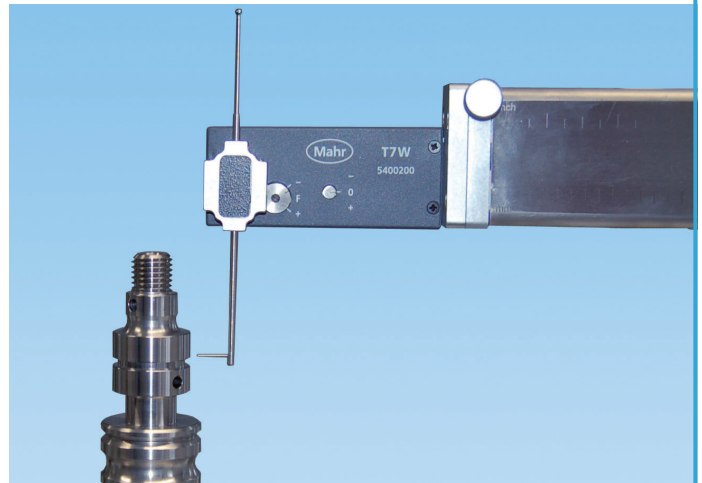

T7W with roughness probe arm

Delivery Scope

Scope of delivery with option Roughness Measurement for MMQ 200 or MMQ 400-2

Combined hardware und software package for roughness measurement and evaluation on MarForm MMQ 200 or MMQ 400-2 with motorized T7W probe including:

Hardware package

- PHT 6-350 pick-up with a 90° stylus tip of radius 2 μm
- Double probe arm holder for PHT 6 as well as the probe arm for form measurement
- Adapter for connecting PHT 6 to MarForm MMQ

Software package

- Software license for evaluating surface roughness with AdvancedForm
- AdvancedForm software for use with MMQ

Technical Data

Pick-up PHT 6-350

System
Skid radius
laterally 2.9 mm
Contact point
Measuring range
Specification

Order No. 6111520

One-skidded probe
In tracing direction 25 mm,

0.8 mm in front of the probe tip
350 μm

For level surfaces, for bores from 6 mm \varnothing to 17 mm depth, grooves from 3 mm width, min. workpiece length = tracing length + 1 mm
2 $\mu\text{m}/90^\circ$ diamond

Probe tip geometry

Motorized probe T7W

Technical data on pg. 16-20

Order no. 5400200

Accessories for MarForm

The optimum solution using accessories



Manual T20W Probe

The inductive **T20W** probe is universally applicable. The fact that the probe arm can be moved in a range of 190° and that there are a variety of damping options for the probe means that measurements can also be performed in areas that are difficult to access. You can combine easily exchangeable probe arms with a variety of styluses in order to adapt the probe to the relevant measurement tasks or workpieces.

T20W probe with probe arm range of 190°

- Measuring range $\pm 1,000 \mu\text{m}$
- Measuring force adjustable from 0.01 N to 0.12 N
- Switchable measuring direction
- Exchangeable probe arm
- Free travel limitation adjustable in contacting direction
- Clamping shaft dia. 8 mm (0.31 in)



Motorized T7W Probe

The **T7W probe** is fitted with a motorized rotational axis. This makes it possible to move the probe arm gradually to the required contacting position. As a result, measurements can be performed on cylindrical surfaces and end faces. As a zero position probe, the **T7W** can also switch automatically between internal and external measurements or between end face measurements from above and below without operator intervention. Fully automatic measurement runs on complex workpieces can be carried out without operator intervention too. The probe arms of the **T7W** are exchangeable. Its motorized rotational axis enables the construction of multi-point probe arms – i.e. probe arms with several different contacting elements – making it possible to switch between different stylus ball geometries within a single measurement run.

Motorized T7W probe with probe arm moveable around 360° for MMQ 400, MMQ 400 CNC and MFU 100

- Total range of $2,000 \mu\text{m}$ (0.079 in)
- Zero probe working range $\pm 500 \mu\text{m}$ (0.02 in)
- Measuring force adjustable from 0.01 N to 0.2 N
- Two-way measuring direction
- Contacting angle freely selectable in 1° steps
- 360° adjustable (motorized)
- Probe arms easily exchangeable (magnetic mount)
- Flexible multi-point probe possible
- Mechanical and electrical overload protection

Accessories for T7W

Probe arm module set with adjustment device (see picture on left)



Accessories for MarForm

The optimum solution using accessories



Clamps

Three-jaw chuck, dia. 100 mm (3.94 in)

with mounting flange dia. 160 mm (6.30 in) and reversible jaws for external and internal clamping. External clamping range 1 to 100 mm (0.040 to 3.93 in), internal 36 to 90 mm (1.42 to 3.54 in). Total height with flange 47 mm (1.85 in). Adjustment by means of rotating ring.

Rim chuck with 8 jaws, dia. 150 mm (5.91 in)

with mounting flange dia. 198 mm (7.80 in) and separate jaws for external and internal clamping. External clamping range 1 to 152 mm (0.039 to 5.98 in), internal 24 to 155 mm (0.94 to 6.10 in). Total height with flange 52 mm (2.05 in). Cannot be used with MMQ 10/MMQ 100 Formtester.

Three-jaw chuck, dia. 110 mm (4.33 in) (not illustrated)

with mounting flange dia. 164 mm (6.46 in). External clamping range 3 to 100 mm (0.12 to 3.94 in), internal 33 to 100 mm (1.29 to 3.94 in). Total height with flange 73 mm (2.87 in).

Three-jaw chuck, dia. 80 mm (3.14 in)

with mounting flange dia. 124 mm (4.88 in). External clamping range 2 to 78 mm (0.079 to 3.07 in), internal 26 to 80 mm (1.02 to 3.15 in). Total height with flange 65.5 mm (2.58 in). Adjustment by means of T-wrench.

Quick-clamping device (collet chuck)

Dia. 1 to 12 mm (0.039 to 0.47 in) with mounting flange dia. 124 mm (4.88 in), for external clamping. Supplied with collet chucks of dia. 1 to 8 mm (0.039 to 0.31 in) in 0.5 mm (0.02 in) steps. Total height 80 mm (3.15 in).

Further collet chuck devices are available on request.

Clamping disks/clamping jaws

Clamping disk set. Adjustable workpiece stop for pre-centering and clamping in series measurements.

For clamping diameter of 36 to 232 mm (1.42 to 9.13 in) depending on machine type. Comprises two stop disks with slot and an eccentric clamping disk.

Clamping jaws (2). With M5 fastening thread. Clamping height 40 mm (1.57 in).

Further part-specific clamps are available on request.

Test Standards

Roundness standard, 40 nm

Ultra-precise measuring sphere for testing measuring spindle radial run-out accuracy. Dia. approx. 50 mm (1.97 in). Roundness deviation 0.04 μm (1.57 μin).

Roundness standard, 100 nm (not illustrated)

High-precision measuring sphere for testing measuring spindle radial run-out accuracy. Dia. approx. 12.7 mm (0.5 in). Roundness deviation 0.10 μm (3.94 μin).

Optical flat

Dia. 150 mm (5.91 in), for testing and adjusting the horizontal measuring unit relative to the measuring spindle axis. Flatness deviation 0.2 μm (8 μin).

Universal cylinder square with calibration standard

High-precision cylinder square with two surfaces for dynamic testing of probe calibration. Dia. 20 mm (0.79 in), length 150 mm (5.91 in).

Cylinder square

for checking and adjusting the measuring spindle axis relative to the Z-axis. Length 250 mm (9.84 in), dia. 80 mm (3.15 in). Deviation from cylindricity max. 1 μm (40 μin). Weight approx. 11.5 kg (25.35 lbs).

Cylinder square (not illustrated)

for checking and adjusting the measuring spindle axis relative to the Z-axis. Length 360 mm (14.17 in), dia. 100 mm (3.94 in). Deviation from cylindricity max. 1 μm (40 μin). Weight approx. 13 kg (28.66 lbs).

Magnification standard with a flattened section (not illustrated)

Cylinder L = 50 mm (1.97 in), dia. 20 mm (0.79 in) with minimally flattened section for testing probe sensitivity.

Multi-wave standard (not illustrated)

Cylindrical base unit with sinusoidal waves on outside diameter. 15, 50, 150 and 500 upr. Used to test the sensitivity of the probesignal and the filters in form testing.